



RÔTISSERIE

SPECIAL-MARKET

1175.6SMAG/SMAiG



DESIGN

The SPECIAL MARKET range of rotisseries have been designed with performance, practicality and mobility in mind. Light weight and compact they are the ideal rotisserie for markets and food trucks and offer a rapid output together with cooking quality.

Conscious of the cost involved for our clients, the SPECIAL MARKET rotisserie has energy saving infrared burners, patented by Rotisol, that enables the rapid roasting of a variety of products.

FEATURES

- ❑ Independent motors
- ❑ Spits with Bakelite handles
- ❑ Optional lighting
- ❑ Independent infrared burners with interchangeable ceramic bricks
- ❑ 2 tempered glass doors (removable for transport)
- ❑ Optional personalised removable roof signage
- ❑ Equipped with bottom drip tray with drainage tap

FINISHES

Standard model in finished STAINLESS STEEL. A choice of front coloured panels are available



1175.6SMAG

Black front panels and stainless steel finish



ACCESSORIES

A variety of accessories are available for the unit. Video of available [accessories](#).

CUI1175 Anti-cutting prongless spit.		BP1175 Chicken spit.		BRC1175 Basket spit.	
BS1175 Sabre spit for ham / turkey.		BRRO1175 Roast-clamp spit.		AT Gas lighter.	
BCR1175 Spatchcock chicken spit.		GSV1175 Raised rack for meat storage.		DEC Spit mover.	

Front view

Rotisserie with roof (optional) and base on casters (optional)

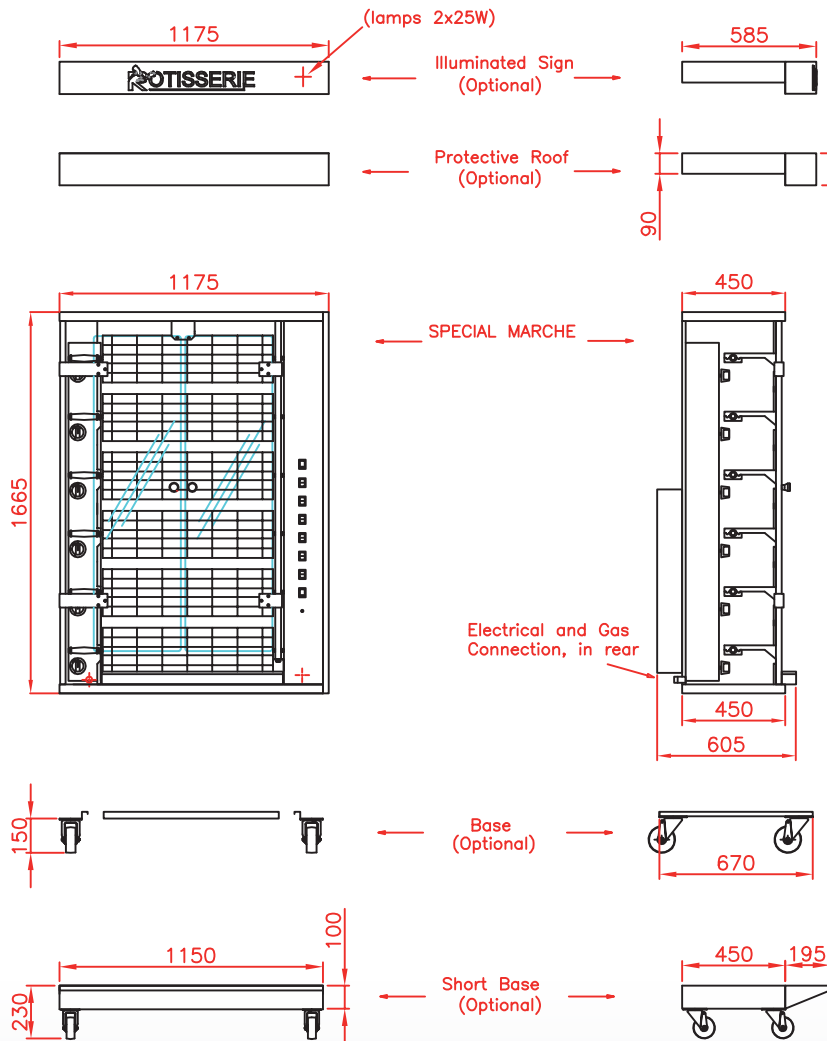

Side view

Rotisserie with roof (optional) and base on casters (optional)

Top view

Rotisserie with roof (optional) and base on casters (optional)

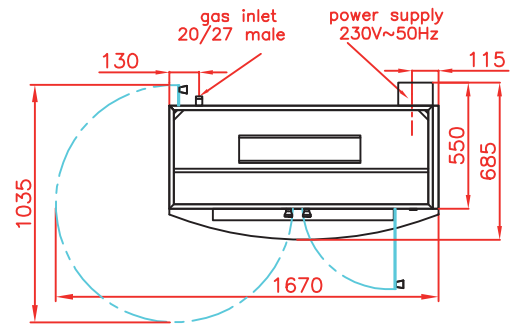

1175.6SMAiG

Stainless steel finish



SPECIFICATIONS

Gas Power	22.5 kW
Gas consumption	Natural gas : 2.25 m ³ /h ; Propane : 1.74 kg/h
Gas connection	20/27 male
Electricity	230 V 50/60 Hz + earth 0.53 kW
Capacity	18/24 open poultries (depending on size)
Warranty	1 year on parts (excluding glass doors)
Extraction	Compulsory
Minimum clearance	51 cm on the left, 5 cm on the right, 10 cm at the rear
Weight	170 kg without packing

Revised : June 2014

DISTRIBUTOR / AGENT

Rotisol S.A.S.

Zone industrielle La Trentaine, Avenue Gustave Eiffel

77507 Chelles cedex - FRANCE

s.bennell@rotisol.com - Tel : +33 1 64 21 80 00

www.rotisol.com