

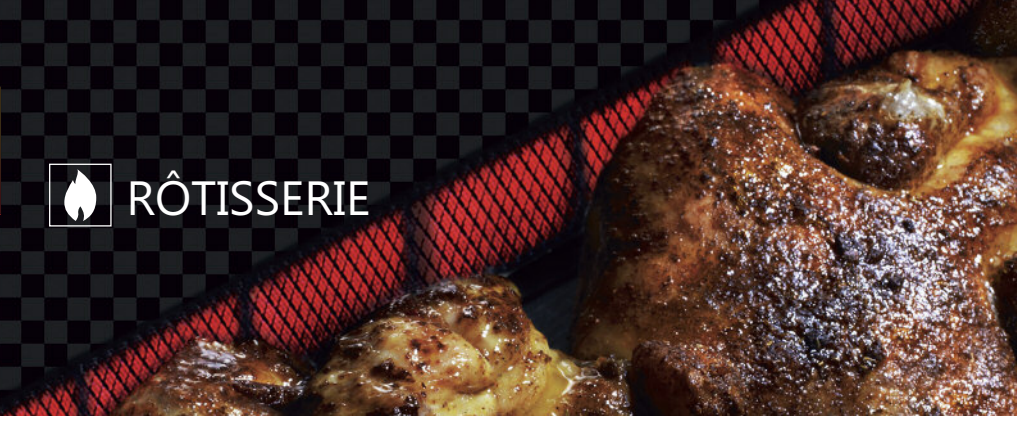

RÔTISSERIE

# SPECIAL-MARKET

## 1175.6SMG/SMiG



### DESIGN

The SPECIAL MARKET range of rotisseries have been designed with performance, practicality and mobility in mind. Light weight and compact they are the ideal rotisserie for markets and food trucks and offer a rapid output together with cooking quality.

Conscious of the cost involved for our clients, the SPECIAL MARKET rotisserie has energy saving infrared burners, patented by Rotisol, that enables the rapid roasting of a variety of products.

### FEATURES

- ❑ Independent motors
- ❑ Spits with Bakelite handles
- ❑ Optional lighting
- ❑ Independent infrared burners with interchangeable ceramic bricks
- ❑ 2 tempered glass doors (removable for transport)
- ❑ Optional personalised removable roof signage
- ❑ Equipped with bottom drip tray with drainage tap

### FINISHES

Standard model in finished STAINLESS STEEL. A choice of front coloured panels are available











**1175.6SMG**

Black front panels and stainless steel finish

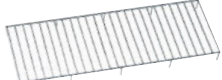

### ACCESSORIES

A variety of accessories are available for the unit. Video of available [accessories](#).

<b>CUI1175</b> Anti-cutting prongless spit.		<b>BP1175</b> Chicken spit.		<b>BRC1175</b> Basket spit.	
<b>BS1175</b> Sabre spit for ham / turkey.		<b>BRRO1175</b> Roast-clamp spit.		<b>AT</b> Gas lighter.	
<b>BCR1175</b> Spatchcock chicken spit.		<b>GSV1175</b> Raised rack for meat storage.		<b>DEC</b> Spit mover.	

### Front view

Rotisserie with roof (optional) and base on casters (optional)

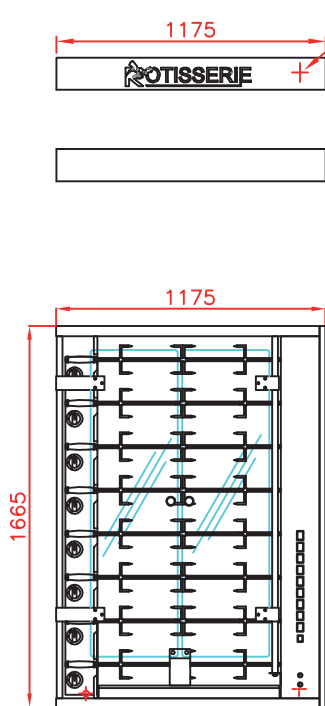

### Side view

Rotisserie with roof (optional) and base on casters (optional)

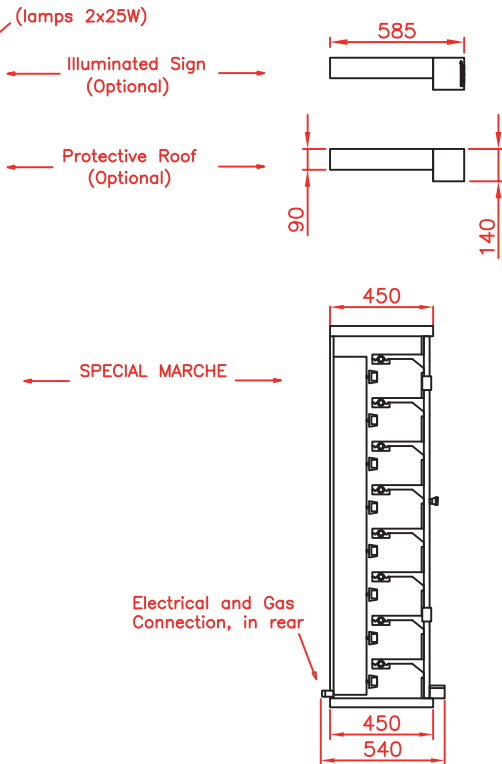

### Top view

Rotisserie with roof (optional) and base on casters (optional)

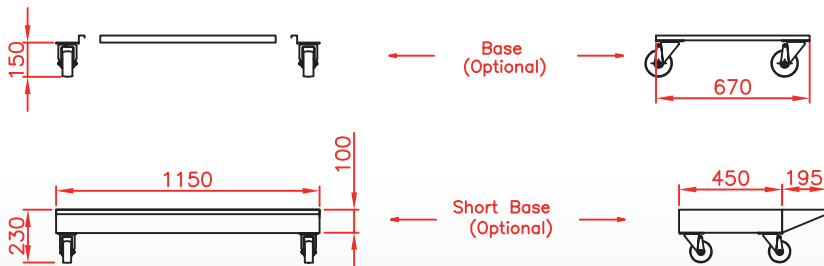
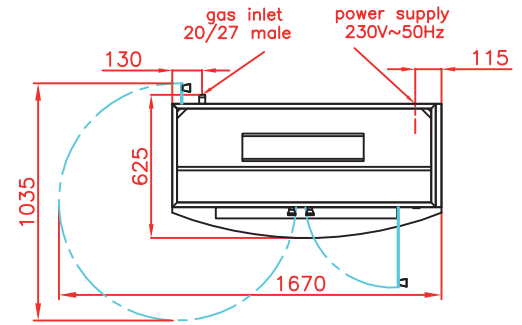

**1175.6SMiG**

Stainless steel finish



Revised : June 2014

## SPECIFICATIONS

<b>Gas Power</b>	22.5 kW
<b>Gas consumption</b>	Natural gas : 2.25 m <sup>3</sup> /h ; Propane : 1.74 kg/h
<b>Gas connection</b>	20/27 male
<b>Electricity</b>	230 V 50/60 Hz + earth 0.53 kW
<b>Capacity</b>	24/30 poultries (depending on size)
<b>Warranty</b>	1 year on parts (excluding glass doors)
<b>Extraction</b>	Compulsory
<b>Minimum clearance</b>	51 cm on the left, 5 cm on the right, 10 cm at the rear
<b>Weight</b>	135 kg without packing

**DISTRIBUTOR / AGENT**

**Rotisol S.A.S.**

Zone industrielle La Trentaine, Avenue Gustave Eiffel

77507 Chelles cedex - FRANCE

[s.bennell@rotisol.com](mailto:s.bennell@rotisol.com) - Tel : +33 1 64 21 80 00

[www.rotisol.com](http://www.rotisol.com)