

Millenium

975.8MLE/MSE + i

DESIGN

Rotisol's most popular line, the Millenium combines the beauty of elegant finishes with the highest degree of functionality and cooking quality.

A wide array of spits allow the chef to cook anything that can be roasted: whole or split chickens, lamb, beef roasts and steaks, cuts of pork, porchetta, fish, vegetables, even fruit.

The optional Vertical Spit System with its choice of eight hanging accessories expands the menu possibilities even more and adds additional visual appeal.

FEATURES

- Energy efficient
- Tempered K-glass doors
- Independent motor for each spit
- Equipped with bottom drip tray with built-in drainage
- Reinforced and anti warping heating element
- Powerful halogen lamps
- Delivered with 8 prongless spits (CUI975)
- Illuminated sign «Rotisserie» for enamel model only
- Base on casters with brakes

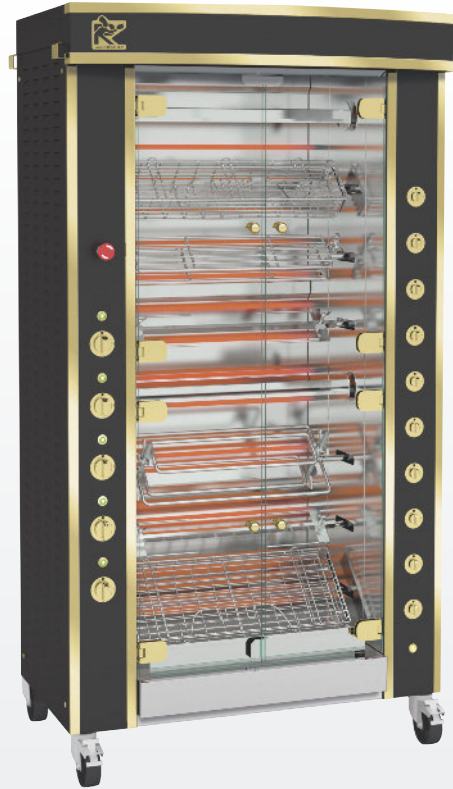



975.8MLE
Black enamel and brass



TECHNICAL DETAILS

Overview of some of the standard features.

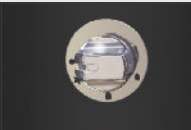
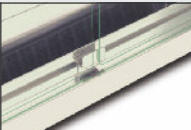
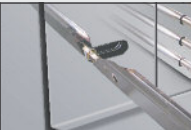
	Reinforced heating elements with stainless steel holders to keep them in place and removable stainless steel panels for easy cleaning.		Emergency stop button type «punch» easily accessible.		Easy and protected access to the compartment of connections and electrical components.
	Switches, in chromed or brass-colored metal		Anti-scald K-glass reduces external thermal radiation (energy saving). Glass overlaps drip pan to keep splatters inside (anti-slip rotation).		Removable inside side-panels doubles protection from grease seeping into motors and other sensitive parts

ACCESSORIES

A variety of accessories are available. See video of available [accessories](#) and of [vertical spit system](#) online.

CUI975 Anti-cutting prongless V-spit.		BP975 Chicken spit.		BRC975 Rectangular basket spit.	
BS975 Spit for ham / turkey.		BRRO975 Roast-clamp spit.		BA975 Lamb/suckling-pig spit.	
BCR975 Spatchcock chicken basket.		DEC Spit mover.		PID975 tray for unspitting.	

Front view

Rotisserie with roof (optional) and base on casters (optional)

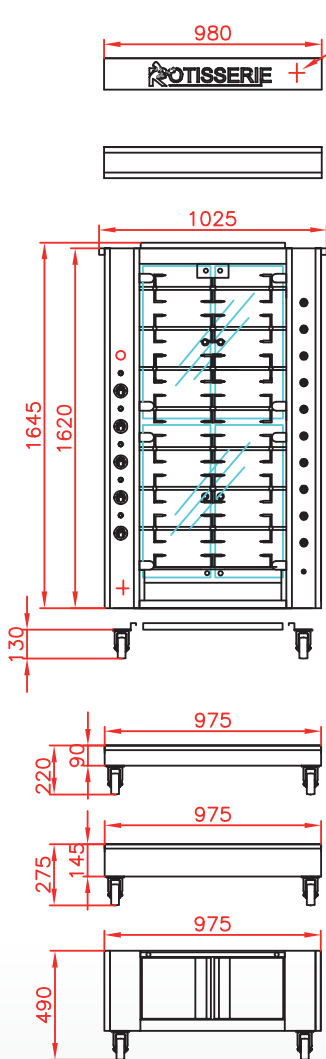

Side view

Rotisserie with roof (optional) and base on casters (optional)

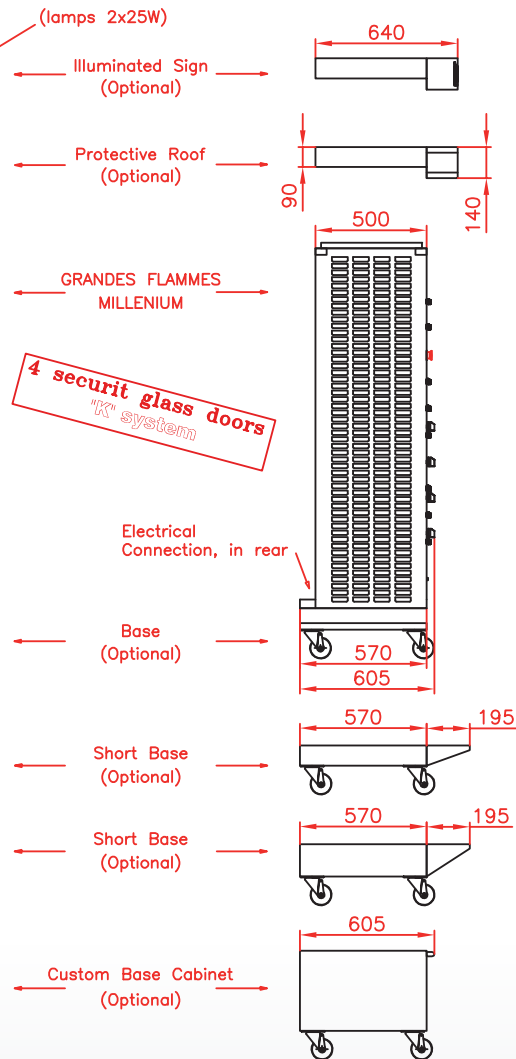

Top view

Rotisserie with roof (optional) and base on casters (optional)

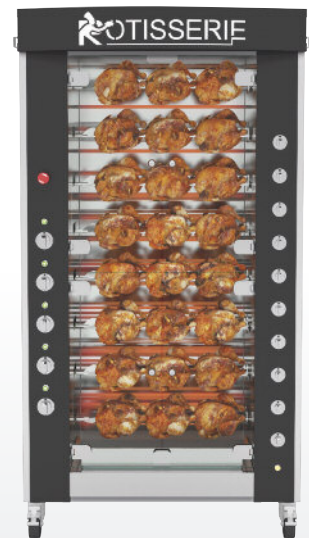
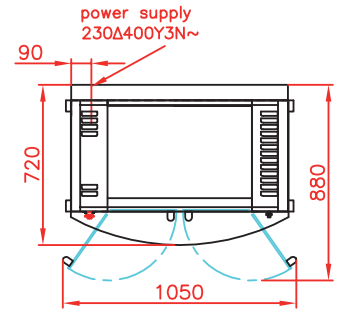

975.8MSE

Stainless steel with black enamel and chrome

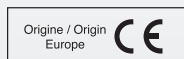

Revised :
December 2016



SPECIFICATIONS

Capacity	16/24 poultries
Power supply	400 Volts 3 phases+neutral+earth
Electrical power	21.49 kW
Weight and size (HxDxW)	195 kg ; 1840 x 720 x 1025 mm
Shipping weight and size	256 kg ; 2000 x 760 x 1070 mm
Guarantee	1 year parts

DISTRIBUTOR / AGENT

Rotisol S.A.S.

Zone industrielle La Trentaine, Avenue Gustave Eiffel

77507 Chelles cedex - FRANCE

s.bennell@rotisol.com - Tel : +33 1 64 21 80 00

www.rotisol.com