

### FlamBoyant™ FB1160-4E

#### DESIGN

The FlamBoyant range of rotisseries has been especially designed for high-volume cooking with high output and speed, while retaining excellent cooking quality. Well designed, user friendly and reliable the FlamBoyant is used by leading supermarkets and chain restaurants throughout the world.

Conscious of the high energy cost involved for our clients, the FlamBoyant rotisserie has energy saving infrared burners, patented by Rotisol. A wide array of accessories enable the rapid roasting of a variety of products.

#### FEATURES

- Energy efficient
- Tempered K-glass doors
- Independent motor for each spit
- Equipped with bottom drip tray with built-in drainage
- Reinforced and anti warping heating element
- Powerful halogen lamp
- Delivered with 4 prongless spits (CUI1160)
- Illuminated sign «Rotisserie» for enamel model only
- Base on casters with brakes



FB1160-4E-SSP  
Black enamel

#### TECHNICAL DETAILS

Overview of some of the standard features.

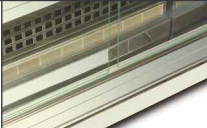
	Independent motors adjustable in depth for each spit.		Robust hinges designed for heavy use, with integrated locking in open and closed positions.		Easy and protected access to the compartment of connections and electrical components.
	Reinforced heating elements with stainless steel holders to keep them in place and removable stainless steel panels for easy cleaning.		Anti-scald K-glass reduces external thermal radiation (energy saving). Glass overlaps drip pan to keep splatters inside (anti-slip protection).		Removable inside side-panels doubles protection from grease seeping into motors and other sensitive parts.

#### ACCESSORIES

A variety of accessories are available. See video of available accessories and of vertical spit system online.

<b>CUI1160</b> Anti-cutting prongless V-spit.		<b>BP1160</b> Porchetta spit.		<b>BRC1160</b> Rectangular basket spit.	
<b>BS1160</b> Spit for ham / turkey.		<b>BRRO1160</b> Roast-clamp spit.		<b>BA1160</b> Lamb/suckling-pig spit.	
<b>BCR1160</b> Spatchcock chicken basket.		<b>DEC</b> Spit mover.		<b>PID1160</b> Tray for unspitting.	

**Front view**  
Rotisserie with roof

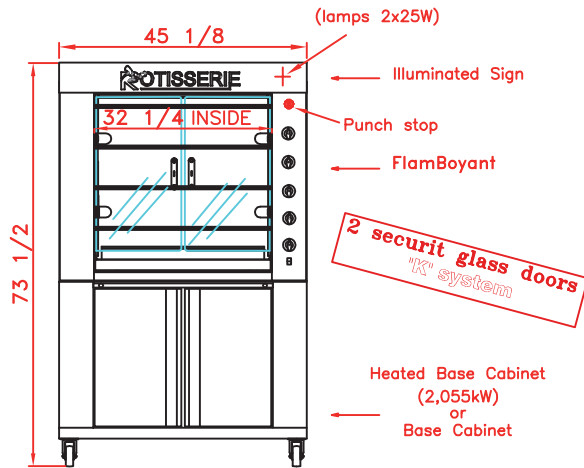

**Top view**  
Rotisserie with roof

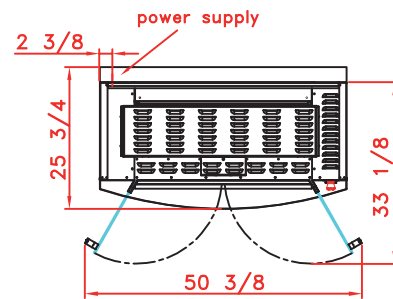

**Side view**  
Rotisserie with roof

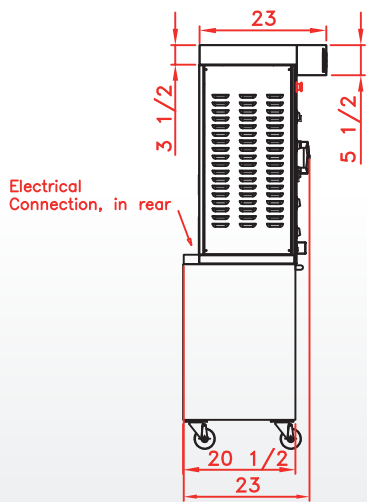

Revised :  
October 2020

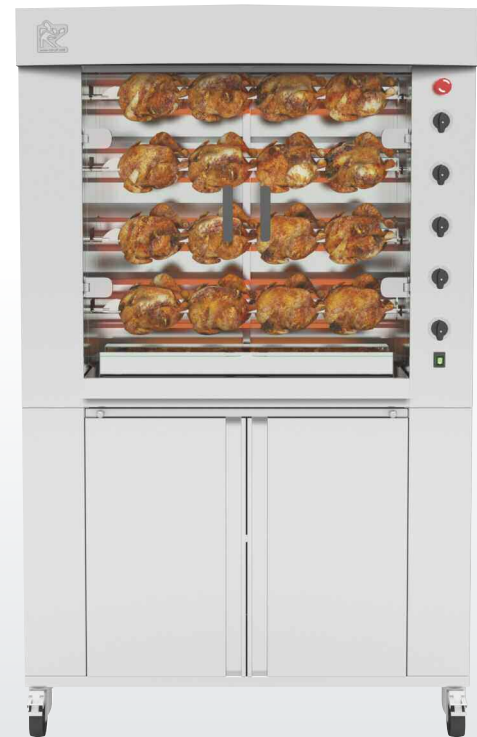

FB1160-4E-SS  
Stainless steel

## SPECIFICATIONS

Capacity	16/20 chickens
Power supply	208-240V-60Hz ; 48,83 Amps
Electrical power	13,36 kW
Weight and size (HxDxW)	375 Lbs ; 73 1/2 x 25 3/4 x 45 1/8 inches
Shipping weight and size	500 Lbs ; 78 3/4 x 29 1/2 x 47 5/8 inches
Warranty	1 year parts and labor

DISTRIBUTOR / AGENT

Rotisol France, Inc.  
415 W. Walnut St. Gardena, CA 90248  
[info@rotisolusa.com](mailto:info@rotisolusa.com)  
Ph :310 671 7254  
Fax :310 671 8071